



SMARTSIDE®
TRIM & SIDING

TRIM AND FASCIA
190, 440, 540, 2000 SERIES

GENERAL

- There are no National Standards for wood composite substrate trim.
- LP SmartSide trim and fascia can be applied directly over materials such as siding, or nailed directly to structural members up to 24 in. O.C.
- All fascia must be supported with solid wood subfascia. **Strand based fascia may be installed without subfascia if it is 6 in. 540 series or larger.**
- TRIM MUST NOT BE IN DIRECT CONTACT WITH MASONRY, CONCRETE, BRICK, STONE, STUCCO OR MORTAR.
- Minimum 6 in. clearance must be maintained between trim and finish grade.
- Trim applied adjacent to porches, patios, walks, etc. must have a clearance of at least 1 in. above any surface where water might collect. The surface must be sloped or otherwise designed to provide proper drainage so the trim is at no time directly exposed to standing water.
- Trim and fascia are not designed for siding; or structural applications and should not be used as a structural member in construction such as a trellis, railing or fencing.
- A non-corrosive drip-edge or drip-cap must be applied at bottom edge of roofing where it meets the fascia.
- Trim and fascia must not be applied to green or crooked structural framing members. Do not apply trim and/or fascia over rain soaked or buckled sheathing materials.
- **DO NOT USE STAPLES**

STORAGE

- Store off the ground on a flat surface, under a roof or separate waterproof covering.
- Keep trim and fascia clean and dry. Inspect prior to application.

MOISTURE

- Moisture control and water vapor control are critical elements of proper housing design. Check your local building codes for application procedures for handling moisture and water vapor in your area.
- Follow all applicable building code specifications relating to prevention of moisture intrusion into the wall assembly. LP SmartSide trim and fascia is a wood product, and, as with all wood products, must be kept free from constant sources of moisture. Lack of proper ventilation; exposure to repetitive sources of water such as sprinklers, condensation, inadequate flashing; improper sealing; or failure to follow common building practices that prevent moisture intrusion into the wall-system; may cause damage, and will void the warranty.

CUTTING

- For the cleanest cut and longer blade life, a fine-tooth carbide tipped blade is recommended.
- Trim and fascia are manufactured with a special edge coating which reduces moisture-related issues. Avoid ripping and routing the trim and fascia, as it will leave the edges unprotected. If the trim or fascia materials must be ripped you must, take special care to prime, paint and seal all exposed wood fiber as described in the finishing section.

GAPS, SEALANT & JOINTS

- Seal all gaps with a high-quality, non-hardening, paintable sealant. Follow the sealant manufacturer's instructions for application.
- Use a high-quality exterior sealant meeting the ASTM C920, minimum Class 25 sealant.

KICK-OUT FLASHING



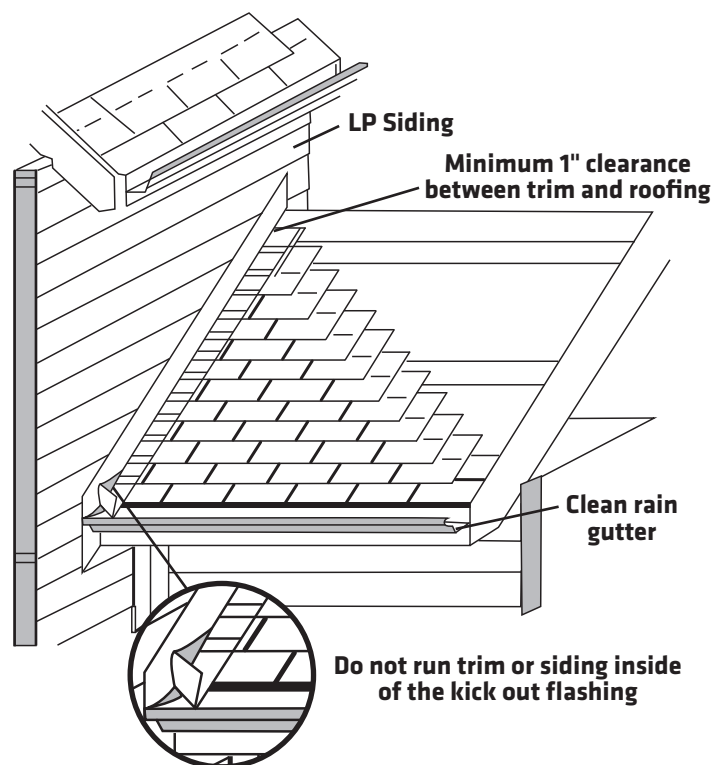







- Install kick-out flashing to direct the water into the gutter
- Install step flashing with minimum 4 in. upper leg
- Properly integrate flashing with the secondary water-resistive barrier. Use housewrap, flashing tape, z-flashing, or other items as needed to maintain the counterflashing principle.
- DO NOT extend the siding or trim into the kick-out flashing or gutter
- Maintain a clearance between the end of the gutter and the adjoining wall to allow for proper maintenance of the siding
- Prime and paint ALL exposed cut edges



Do not run trim or siding inside of the kick out flashing

NAILING INSTRUCTIONS

- Use a minimum 8d (0.113 in. diameter shank), hot-dipped galvanized nail, with a minimum 0.270 in. diameter head.
- Penetrate structural framing or wood structural panels and structural framing a minimum of 1 in.
- Space nails maximum 24 in. O.C. with minimum of 2 nails per stud.
- Leave $\frac{3}{16}$ in. gap where trim butts into other materials and at butt joints, miter joints and ends. Where edges of trim meet siding material, windows, doors or other finished openings, leave a minimum $\frac{3}{16}$ in. gap to allow for proper sealing. Provide increased spacing along the trim if specified by the siding installation instructions.
- Leave 1 in. clearance between trim and roofing materials at roof rake.
- For edge-nailing, all nail holes must be pre-drilled. Do not attempt to edge-nail without pre-drilling.
- When applied as rake, corner or band board, nails must be spaced no further than 12 in. apart on alternating edges. Nails must be $\frac{3}{8}$ in. from the edge.
- Climb cut the surface of the siding such that the rotation of the blade cuts downward on the primed or prefinished surface.
- Where trim butts window, door casings and masonry, etc. leave a $\frac{3}{16}$ in. gap and seal.

CONDITION		CORRECTION
Snug		OK 
Flush		OK 
Visible fiber		Paint 
Countersunk $\frac{1}{16}$ - $\frac{1}{8}$ IN.		Apply sealant 
Countersunk more than $\frac{1}{8}$ in.		Apply sealant and re-nail 

- Attachment of trim as batten strips where the trim is unable to be attached to framing will require additional support from a construction adhesive. Use an exterior grade construction adhesive that meets the following specifications and apply according to the adhesive manufacturer's specifications. Attach the trim mechanically with hot dipped galvanized ring-shank nails no smaller than 0.090 inch shank diameter. The nails must attach the trim sufficiently to secure the trim to the structure while the construction adhesive completes its curing process.

Construction Adhesive Specifications:

- Minimum bond strength: 300 psi
- Minimum application temperature: 40oF
- Paintable grade

Insulated Sheathings

LP SmartSide Siding may be installed over low-compression rigid foam or exterior gypsum. The following precautions must be followed:

- Adequate bracing of the wall in accordance with the International Codes or other ruling building code is required.

- For rigid foam sheathing up to 1 in. (25.4 mm) thick, siding may be nailed directly to the foam sheathing unless a drainage plane is required by the local building code. Nail length must be increased to ensure a minimum 1-1/2 in. (38.1 mm) fastener penetration into the structural framing.
- For rigid foam sheathing greater than 1 in. (25.4 mm), a minimum 1-1/2 in. (38.1 mm) thick by 3-1/2 in. (88.9 mm) wide vertical strapping or furring strip must be installed over the sheathing to provide a solid, level nailing base for the siding. The strapping must be securely fastened to structural framing spaced no greater than 16 in. O.C. (406 mm) with a minimum nail penetration of 1-1/2 in. (38.1 mm) and a maximum nail spacing no greater than the width of the siding.

Louisiana-Pacific will assume no responsibility for any damage or condition arising from the use of rigid foam or exterior gypsum.

FLASHING, WINDOWS, DOORS & OPENINGS

- All openings must be sealed and flashed in a manner that prevents moisture intrusion or water buildup. Several examples that accomplish this are shown.
- In a horizontal brick frieze or band board application where the trim overlaps the masonry leave a $\frac{3}{16}$ -inch minimum airspace or a layer of flashing between the trim and the masonry.
- Horizontal trim or bands shall be flashed with a drip cap to redirect water away from the wall assembly.

Figure 1

INSIDE CORNER DETAIL

Trim must extend beyond face of siding.

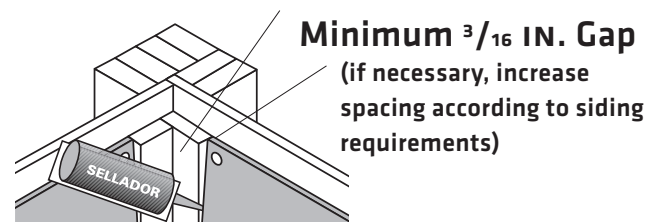

Figure 2

PREFERRED OUTSIDE CORNER DETAIL

Minimum 2 in. overlap space siding $\frac{3}{16}$ in. from corner of wall

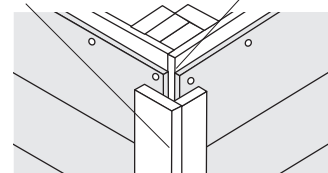

Figure 3

ALTERNATE OUTSIDE CORNER DETAIL

Trim must extend beyond face of siding.

Minimum $\frac{3}{16}$ IN. Gap
(if necessary, increase spacing according to siding requirements)

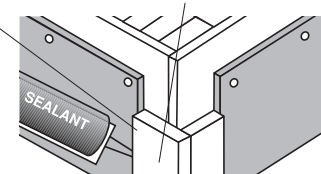
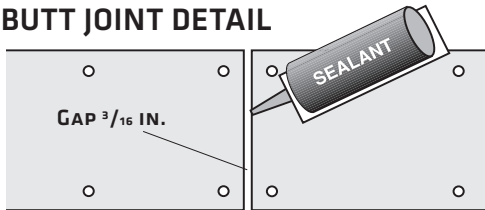

Figure 4

BUTT JOINT DETAIL



JOINT DETAIL

- Ends must be spaced and joints may lightly touch in runs less than 16 feet. Butt joints require a $\frac{3}{16}$ in. gap in runs 16 feet or greater. Seal with a high quality non-hardening paintable long-life sealant.
- Butt joints require four (4) nails with two nails on either side of the joint at each edge.

Figure 5

DOORS & WINDOWS

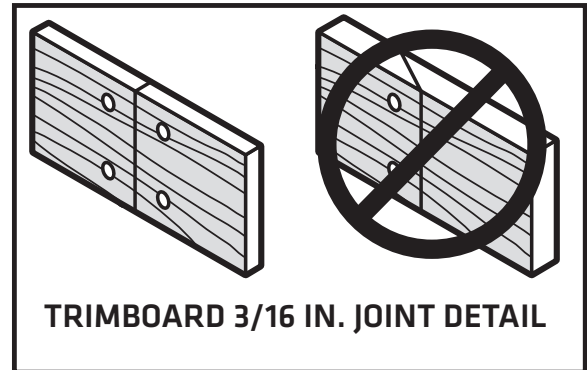
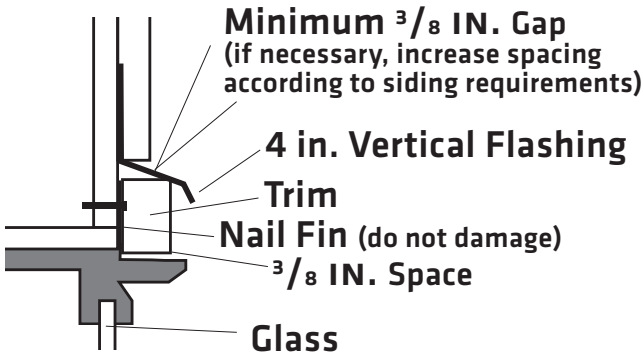

Figure 8

- Do not use scarf joints.

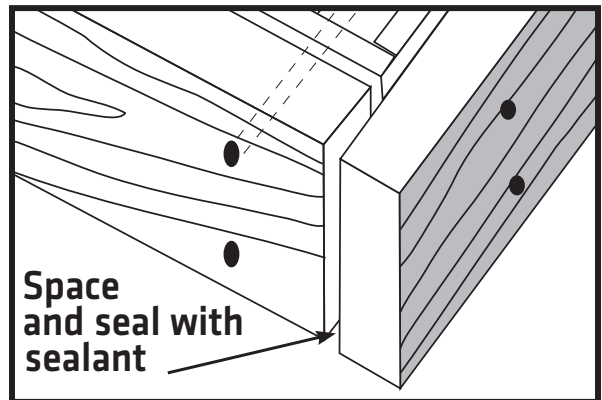

Figure 9

- End-to-end joints in vertical trim should be installed so that they shed water.
- **Do not miter corner joints of band boards, fascia, etc.**
- Allow the end of the trim to lap over the end of the adjoining trim, gap $\frac{3}{16}$ in. and caulk with sealant.

Figure 6

HORIZONTAL TRIM AND BAND BOARD

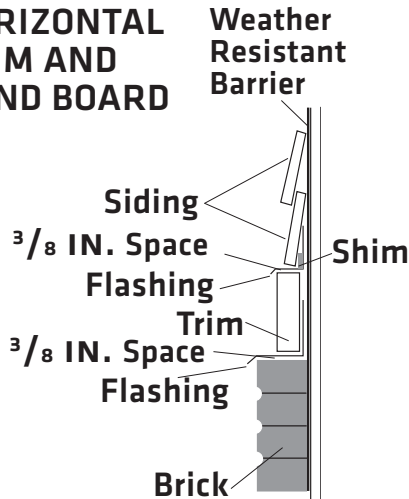
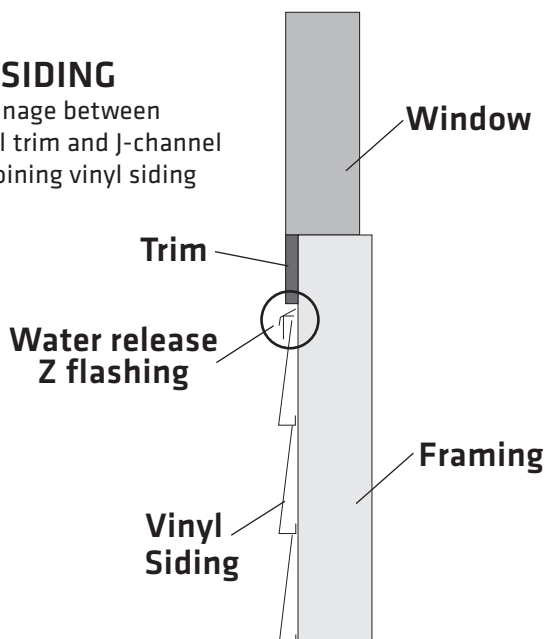

Figure 7

VINYL SIDING

Allow drainage between horizontal trim and J-channel when adjoining vinyl siding



GABLE ENDS

- At gable ends, a backer board (such as a barge rafter) should be used under fascia to provide maximum support along the length of the product (see Figures 10 and 11.)
- If trim and fascia is installed directly to lookouts on an overhanging rake, the lookouts must be installed edgewise and must be spaced no wider than 24 in. O.C. (see Figures 10 and 11). THIS APPLICATION APPLIES TO MINIMUM 6 in. 540 SERIES STRAND TRIM ONLY.

Figure 10

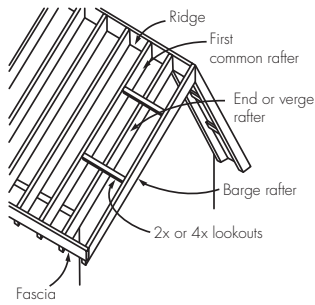

Figure 11

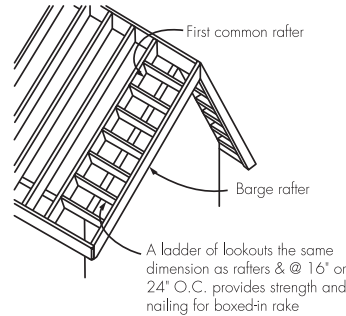
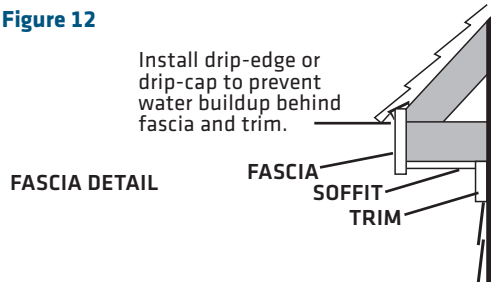

Figure 12



MITERING

- **Do not miter trim edges.** 45 degree mitering of trim ends around door and window openings is acceptable, as well as joining.

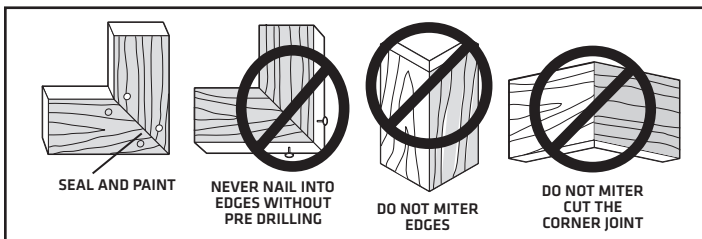

Figure 13

FASCIA AND RAKE BOARDS AT CORNERS

- All joints must be supported by framing.
- Do not nail from the face of one trim member into the edge of another.
- Do not miter cut the corner joint.

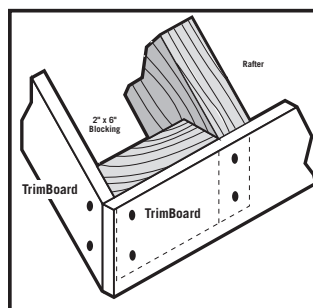

Figure 14

FINISHING

DO

- **Prime and paint all exposed surfaces including all drip edges or where water will hang.**
- Apply finish coat as soon as possible or within 180 days of application.
- High-quality acrylic latex paint, specially formulated for use on wood and engineered wood substrates, is highly recommended. Semi-gloss or satin finish oil or alkyd paints are acceptable. For flat alkyd paint, please check with the coating manufacturer for their recommendations for use on composite wood siding.
- Follow the coating manufacturer's application and maintenance instructions.

DO NOT USE

- Semi-transparent and transparent stains.
- Shake and shingle paints.
- Vinyl-based resin formulas such as vinyl acetate, PVA, vinyl acetate/acrylic copolymer paints.

HANDLE PREFINISHED LP SMARTSIDE PRODUCTS WITH EXTREME CARE DURING STORAGE AND APPLICATION. TOUCH UP ANY DAMAGE TO THE FINISH THAT MAY OCCUR DURING APPLICATION PER PREFINISHERS SPECIFICATIONS.

The Louisiana-Pacific Corporation ("LP") LP SmartSide trim and fascia (the "Products") limited warranty (the "Warranty") applies only to structures on which the Products have been applied, finished and maintained in accordance with the published application, finishing and maintenance instructions in effect at the time of application. The failure to follow such application, finishing or maintenance instructions will void the Warranty as to the portion of the Products affected by the variance (the "Affected Products").

LP assumes no liability for any loss or damage sustained by the Affected Products and is expressly released by the purchaser or owner from any such loss or liability.

Any modification of the Warranty's application, finishing or maintenance requirements is void and unenforceable unless approved in writing prior to application by the Siding General Manager or his designee and a member of the LP Legal Department.

For a copy of the warranty or for installation and technical support, visit the LP SmartSide product support Web site at:

www.lpsmartside.com

or for additional support call 800-450-6106.

WARRANTY REMEDIES ARE NOT AVAILABLE IF REQUIREMENTS ARE NOT FOLLOWED.

Cal. Prop 65 Warning: Use of this product may result in exposure to wood dust, known to the State of California to cause cancer.



©2014 Louisiana-Pacific Corporation. All rights reserved. LP, SmartSide, SilverTech and SmartFinish are registered trademarks of Louisiana-Pacific Corporation. Printed in U.S.A.

NOTE: Louisiana-Pacific Corporation periodically updates and revises its product information. To verify that this version is current, call 800-450-6106.